

DIN - 909

TAPONES CON ARO

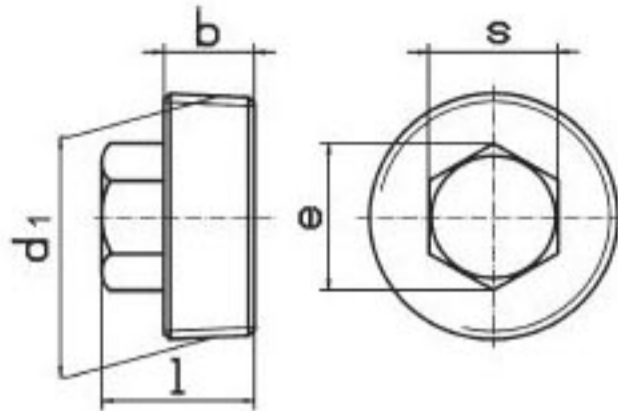

d	b js16	e min.	l js 16	s
M 8 x 1 M 10 x 1 M 12 x 1,5	8 10	7,66 7,66	12,5 15	7 7
M 14 x 1,5 M 16 x 1,5 M 18 x 1,5	10 10 10	9,76 10,89 10,89	15 16 16	9 10 10
M 20 x 1,5 M 22 x 1,5 M 24 x 1,5	10 10 12	14,2 14,2 18,72	17 17 20	13 13 17
M 26 x 1,5 M 30 x 1,5 M 36 x 1,5	12 12 15	18,72 20,88 26,1/	20 22 27	17 19 24
M 36 x 2 M 38 x 1,5 M 42 x 1,5	15 15 18	26,17 26,17 26,17	27 27 30	24 24 24
M 48 x 1,5 M 48 x 2	20 20	32,95 32,95	35 35	30 30

R 1/8"	8	7,66	12,5	7
R 1/4"	10	9,76	15	9
R 3/8"	10	10,89	16	10
R 1/2"	10	14,2	17	13
R 5/8"	12	16,2	20	14
R 3/4"	12	18,72	20	17
R 1	12	20,88	22	19
R 1 1/4"	18	26,17	30	24
R 1 1/2"	20	32,95	35	30
R 1 3/4"	20	32,95	35	30
R 2"	22	39,85	37	30